

A1

2020.08

.....	2
.....	2
.....	3
.....	3
.....	3
.....	4
.....	4
.....	4
.....	6

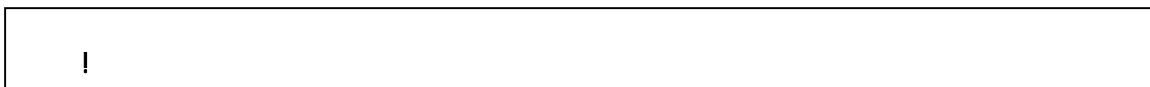
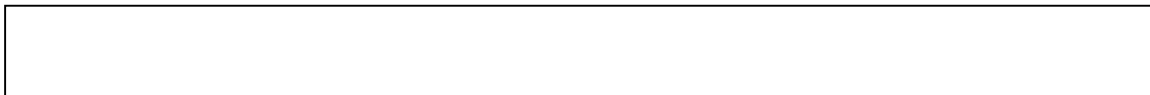

1

2

3)

4)

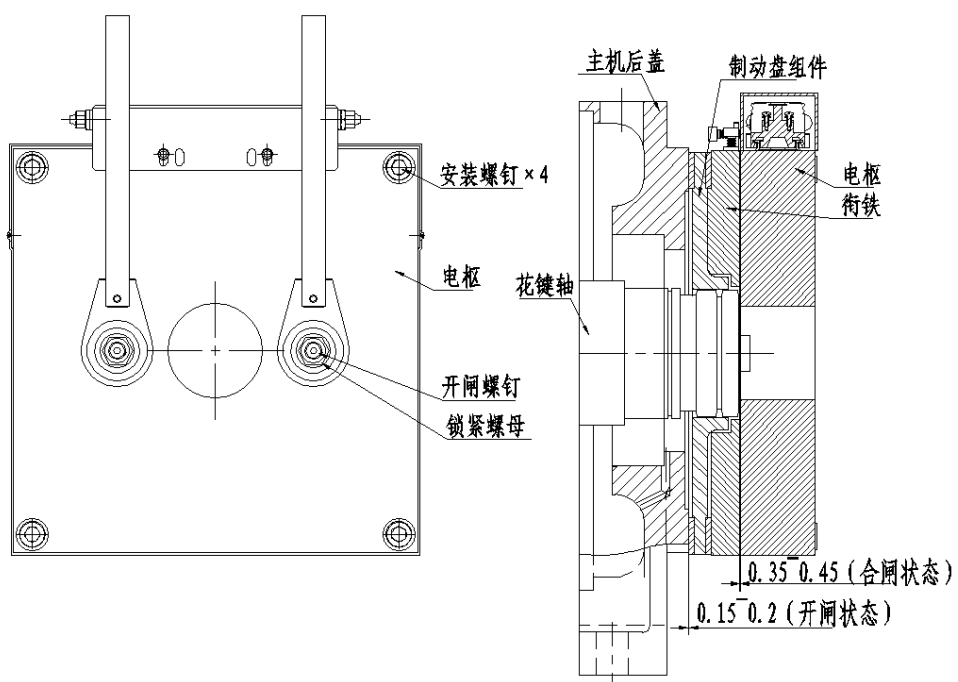

1

2

3

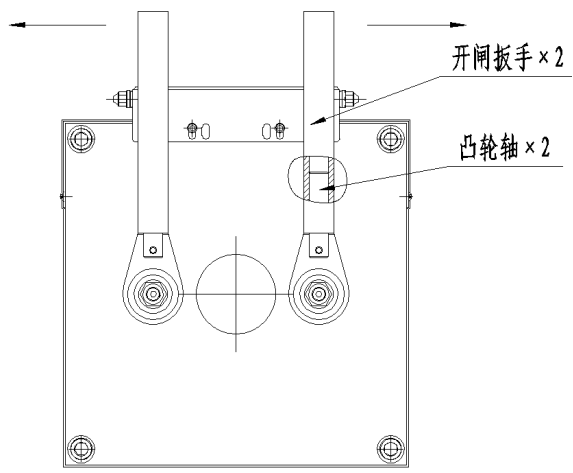

1

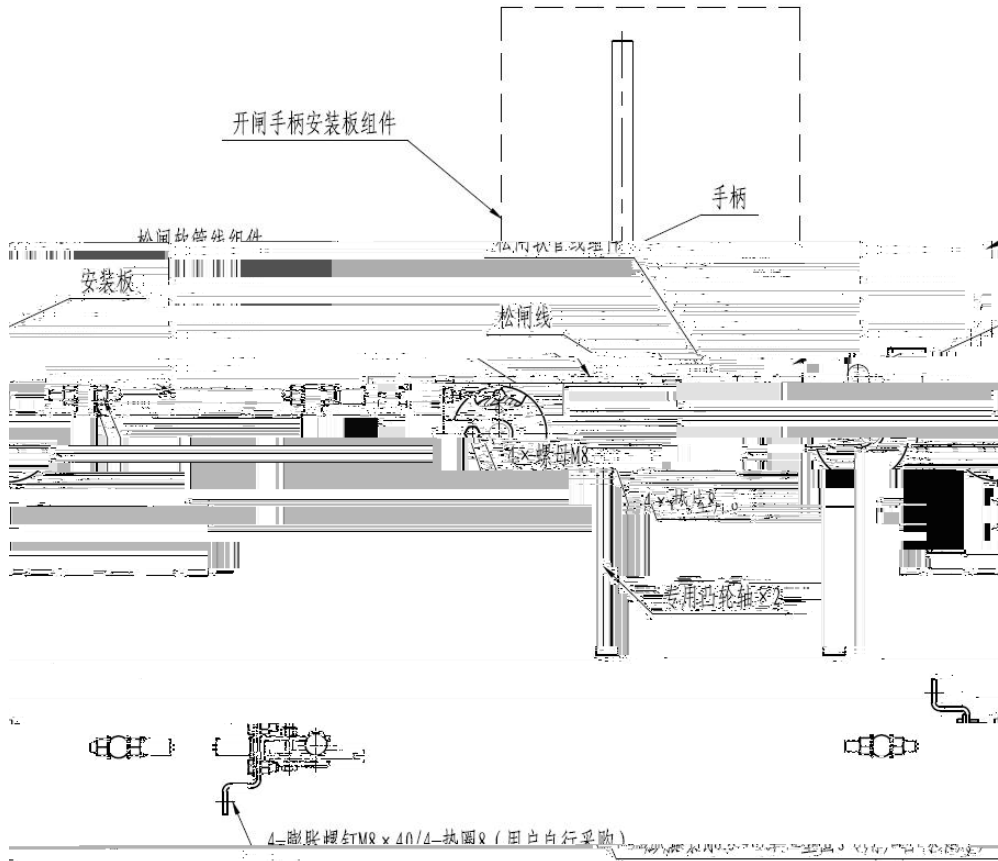

1.3

2

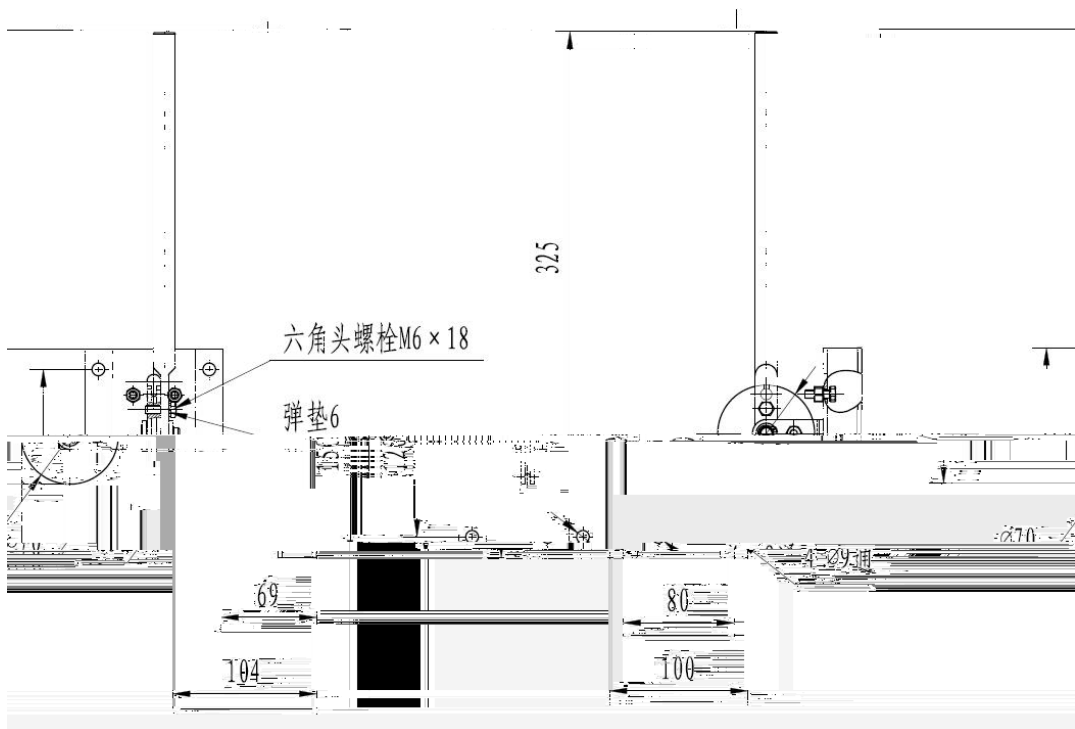

1.4

3

4

5

150%	10
------	----

--